

Hydraulic Separators

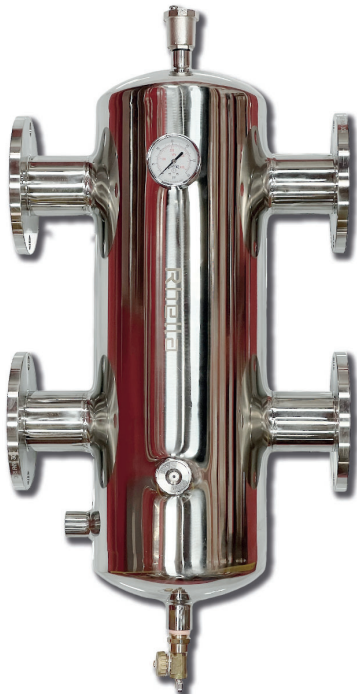

Stainless Steel Hydraulic Separators with Flange Connections



LLH250

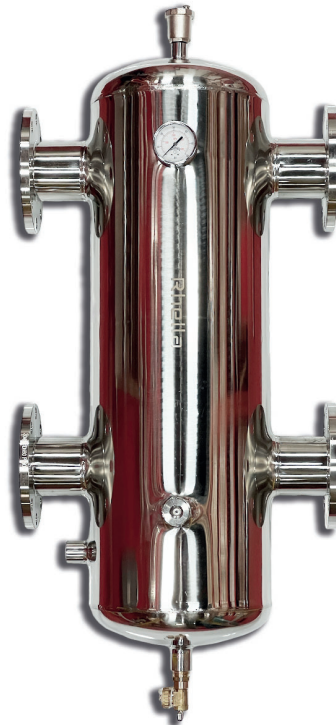

LLH300

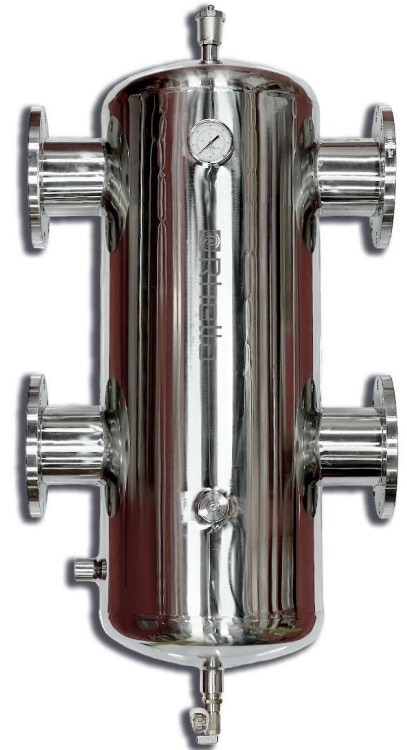

LLH400

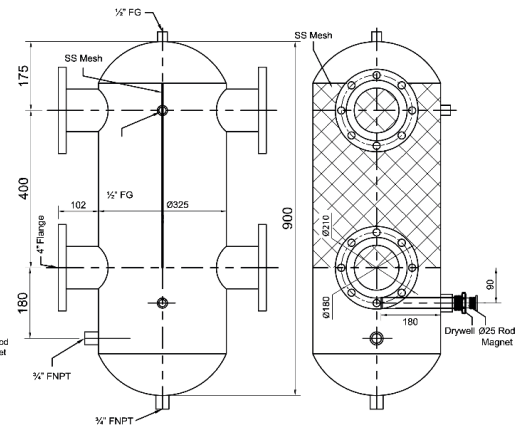
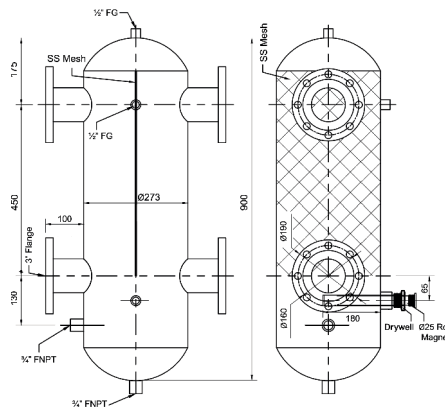
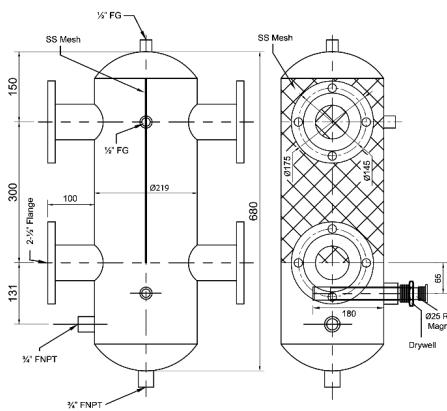

- M50 grade neodymium rod magnets
- 10,000 gauss holding force, temperature rated to 90C
- Max. Operational Pressure, 10 bar/150 PSI
- Operation temperature range, 0-100°C/132-270°F
- Connection for makeup water

Model Number	Flange	Flow Rate	Drain	Makup Water	Magnet Size	Weight
LLH250	2-1/2" DN65 ANSI B16.5 Class 150	60 GPM 4ft/sec	1/2" FNPT	1/2" FNPT		50 Lbs
LLH300	3" DN80 ANSI B16.5 Class 150	92 GPM 4ft/sec	3/4" FNPT	3/4" FNPT		75 Lbs
LLH400	4" DN100 ANSI B16.5 Class 150	160 GPM 4ft/sec	3/4" FNPT	3/4" FNPT		100 Lbs